



Specifications

Large Area Top Dresser

TD-460

<i>General</i>	
Hopper Capacity (struck)	2.12 m ³ (75 ft ³)
Belt	One Piece Vulcanized
Hydraulic Controls	Standard
Machine Finish	Powder Coat Paint
Options Mounting	Swing away finishing brush
Hydraulic Power Pack (option)	PTO Driven

<i>Weights</i>	
Base Model (no options installed)	1,542 kg (3,400 lbs)
Finishing Brush	120 kg (265 lbs)
Hydraulic Power Pack (dry)	82 kg (180 lbs)

<i>Chassis</i>	
Payload (tare)	5,353 kg (11,800 lbs)
GVWR	6,895 (15,200 lbs)
Tire Size	82.5x40x40.25 cm (33x16x16.1 in) 10 ply
Tire Inflation Pressure (max)	172 kPa (25 psi)
Suspension	4 wheel walking beam
Brakes (Electric)	Optional 2 and 4 wheel

Important: These specifications are subject to change without notice. They are provided for reference only. Contact an authorized TYCROP Distributor for up-to-date or additional information.



Specifications Large Area Top Dresser TD-460

<i>Dimensions</i>			
	Length	Width	Height
Overall (no options installed)	4.24 m (167 in)	2.26 m (89 in)	1.63 m (63 in)
Base Model (Shipping)	4.19 m (165 in)	2.26 m (89 in)	1.91 m (75 in)
Finishing Brush (Shipping)	2.16 m (85 in)	0.51 m (20 in)	0.79 m (31 in)
Hydraulic Power Pack (Shipping)	0.84 m (33 in)	0.64 m (25 in)	0.71 m (28 in)

<i>Tow Vehicle Requirements</i>	
Towing Capacity (max. payload)	7,100 kg (15,675 lb)
Tongue Weight (max. payload)	156.5 kg (345 lb)
Minimum Power	34 Kw (45 Hp)
Hitch	25mm (1 in.) dia. safety rated hitch pin and safety clip

<i>Hydraulics</i>	
Recommended Flow (min. no options installed)	23 l/min. (6 US gal/min.)
Recommended Flow (max.)	53 l/min. (14 US gal/min.)
Recommended Input Pressure (min.)	138 bar (2,000 psi)
Recommended Input Pressure (max.)	190 bar (2,800 psi)
Fluid Type	ISO VG-68 or equivalent
Fluid Viscosity	60.09 cSt @ 40C
Fluid Capacity	3 L (0.80 US gal.)
Fluid Capacity with Optional Power Pack	90 L (23.8 US gal.)

Important: These specifications are subject to change without notice. They are provided for reference only. Contact an authorized TYCROP Distributor for up-to-date or additional information.



Specifications

Large Area Top Dresser

TD-460

<i>Electrical System</i>	
Voltage	12V
Amperage Draw	3.3 A
Fuse	15 A

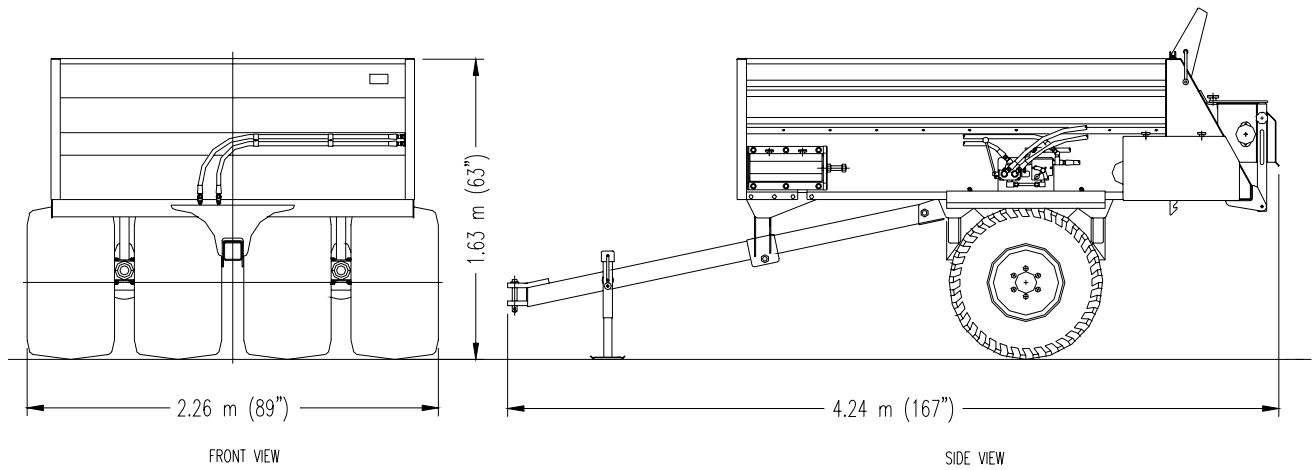

Important: These specifications are subject to change without notice. They are provided for reference only. Contact an authorized TYCROP Distributor for up-to-date or additional information.