



# Specifications ProPass Top Dresser PP-180

<b><i>General</i></b>	
Hopper Capacity (struck)	0.54 m3 (21 ft3)
Hopper Capacity (heaped)	0.71 m3 (25 ft3)
Belt	One Piece Vulcanized Self tracking
Controls	Standard or Electronic
Machine Finish	Powder Coat Paint
Twin Spinner Mounting	Removable without tools
Hydraulic Power Pack (option)	11 Hp

<b><i>Weights</i></b>	
Base Model (no options)	248 kg (546 lbs)
Tow Behind Chassis	218 kg (480 lbs)
Truck Mount Kit	41 kg (90 lbs)
Twin Spinner	65.5 kg (140 lbs)
Vortex Brush	28 Kg (60 lbs)
Truck Mount Storage Stand	30 kg (65 lbs)
Hydraulic Power Pack (dry)	100 kg (220 lbs)

<b><i>Tow Behind Chassis</i></b>	
Payload (tare)	905 kg (2,000 lbs)
GVWR	1,405 (3,100 lbs)
Tire Size	60x32.5x30 cm (24x13x12 in) 4 ply
Inflation Pressure (max.)	124 kPa (18 psi)
Suspension	4 wheel walking beam

Important: These specifications are subject to change without notice. They are provided for reference only. Contact an authorized TYCROP Distributor for up-to-date or additional information.



# Specifications ProPass Top Dresser PP-180

<b><i>Truck Mount</i></b>	
Payload (tare)	289 kg (636 lbs)
GVWR	Do not exceed work vehicle rating

<b><i>Overall Dimensions</i></b>			
	Length	Width	Height
Tow Behind	3.4 m (134 in)	1.7 m (65 in)	1.4 m (56 in)
Truck Mount	1.98 m (78 in)	1.7 m (65 in)	1.4 m (56 in)

<b><i>Tow Vehicle Requirements</i></b>	
Towing Capacity (max. payload)	1,550 kg (3,400 lb)
Tongue Weight (max. payload)	136 kg (300 lb)
Minimum Power	13 Kw (18 Hp)
Hitch	Use 18 mm (0.75 in) dia. safety rated hitch pin and safety clip

<b><i>Hydraulics</i></b>	
Recommended Flow (min.)	23 l/min. (6 US gal/min.)
Recommended Flow (max.)	38 l/min. (10 US gal/min.)
Recommended Input Pressure (min.)	138 bar (2,000 psi)
Recommended Input Pressure (max.)	190 bar (2,800 psi)
Fluid Type	ISO VG-68 or equivalent
Fluid Viscosity	60.09 cSt @ 40C
Fluid Capacity	2 L (0.53 US gal.)
Fluid Capacity with Optional Power Pack	32.9 L (8.7 US gal.)

Important: These specifications are subject to change without notice. They are provided for reference only. Contact an authorized TYCROP Distributor for up-to-date or additional information.



# Specifications ProPass Top Dresser PP-180

<i>Electrical System</i>	
Voltage	12V
Amperage Draw	3.3 A
Fuse	15 A

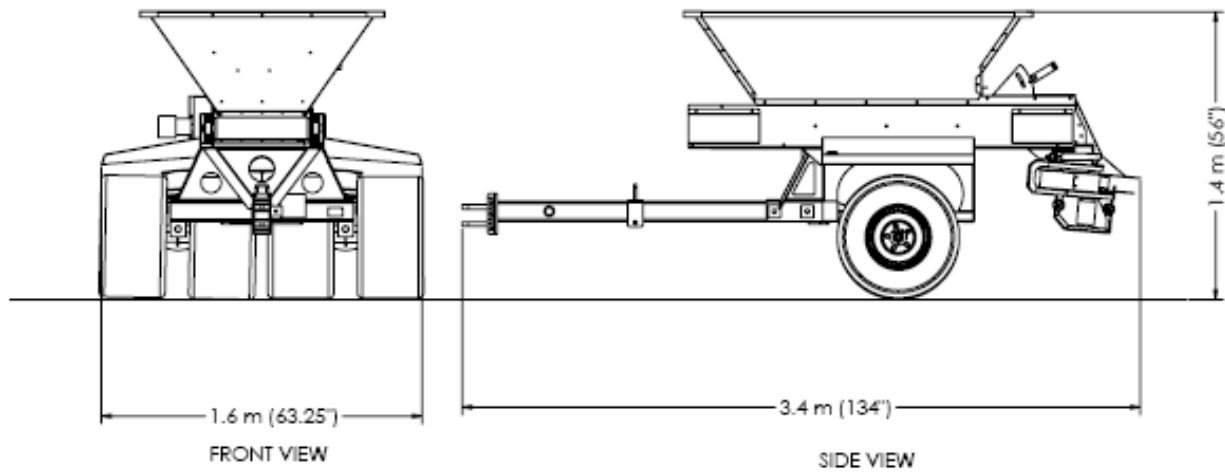

Important: These specifications are subject to change without notice. They are provided for reference only. Contact an authorized TYCROP Distributor for up-to-date or additional information.