



Specifications Material Handling Unit MH-400

| General | |
|-------------------------------|--|
| Hopper Capacity | 3.06 m3 (4 yd3) |
| Main Conveyor Belt | One Piece Vulcanized |
| Hydraulic Controls | Standard or Electronic |
| Machine Finish | Powder Coat Paint |
| Options Mounting | Removable without tools Option Caddy Included |
| Hydraulic Power Pack (option) | PTO Driven |

| Weights | |
|-----------------------------------|---------------------|
| Base Model (no options installed) | 1,360 kg (3000 lbs) |
| Twin Spinner | 95 kg (210 lbs) |
| Cross Conveyor | 132 Kg (290 lbs) |
| Swivel Kit | 72 kg (158 lbs) |
| Hydraulic Power Pack (dry) | 82 kg (180 lbs) |

| Chassis | |
|--------------------------------|---|
| Payload (tare) | 5,353 kg (11,800 lbs) |
| GVWR | 6,713 kg (14,800 lbs) |
| Tire Size | 82.5x40x40.25 cm (33x16x16.1 in) 10 ply |
| Tire Inflation Pressure (max.) | 172 kPa (25 psi) |
| Suspension | 4 wheel walking beam |
| Brakes (Electric) | Optional 2 and 4 wheel |

Important: These specifications are subject to change without notice. They are provided for reference only. Contact an authorized TYCROP Distributor for up-to-date or additional information.



Specifications Material Handling Unit MH-400

| <i>Dimensions</i> | | | |
|---------------------------------|-----------------|----------------|----------------|
| | Length | Width | Height |
| Overall (no options installed) | 4.8 m (190 in) | 1.98 m (78 in) | 2.2 m (86 in) |
| Base Model (shipping) | 3.73 m (147 in) | 2.05 m (81 in) | 2.13 m (84 in) |
| Twin Spinner (shipping) | 1.29 m (51 in) | 1.02 m (40 in) | 0.66 m (26 in) |
| Cross Conveyor (shipping) | 2.08 m (82 in) | 0.76 m (30 in) | 0.36 m (14 in) |
| Swivel Kit (shipping) | 1.22 m (48 in) | 0.76 m (30 in) | 0.43 m (17 in) |
| Hydraulic Power Pack (shipping) | 0.84 m (33 in) | 0.64 m (25 in) | 0.71 m (28 in) |

| <i>Tow Vehicle Requirements</i> | |
|--|--|
| Towing Capacity (max. payload) | 7,175 kg (15,850 lb) |
| Tongue Weight (max. payload) | 148.5 kg (330 lb) |
| Minimum Power | 34 Kw (45 Hp) |
| Hitch | 25mm (1 in.) dia. safety rated hitch pin and safety clip |

Important: These specifications are subject to change without notice. They are provided for reference only. Contact an authorized TYCROP Distributor for up-to-date or additional information.



Specifications Material Handling Unit MH-400

| <i>Hydraulics</i> | |
|---|----------------------------|
| Recommended Flow (min. no options installed) | 23 l/min. (6 US gal/min.) |
| Recommended Flow (min. options installed) | 38 l/min (10 US gal/min.) |
| Recommended Flow (max.) | 53 l/min. (14 US gal/min.) |
| Recommended Input Pressure (min.) | 138 bar (2,000 psi) |
| Recommended Input Pressure (max.) | 190 bar (2,800 psi) |
| Fluid Type | ISO VG-68 or equivalent |
| Fluid Viscosity | 60.09 cSt @ 40C |
| Fluid Capacity | 3 L (0.80 US gal.) |
| Fluid Capacity with Optional Power Pack | 90 L (23.8 US gal.) |
| <i>Electrical System</i> | |
| Voltage | 12V |
| Amperage Draw | 2.98 A |
| Fuse | 15 A |

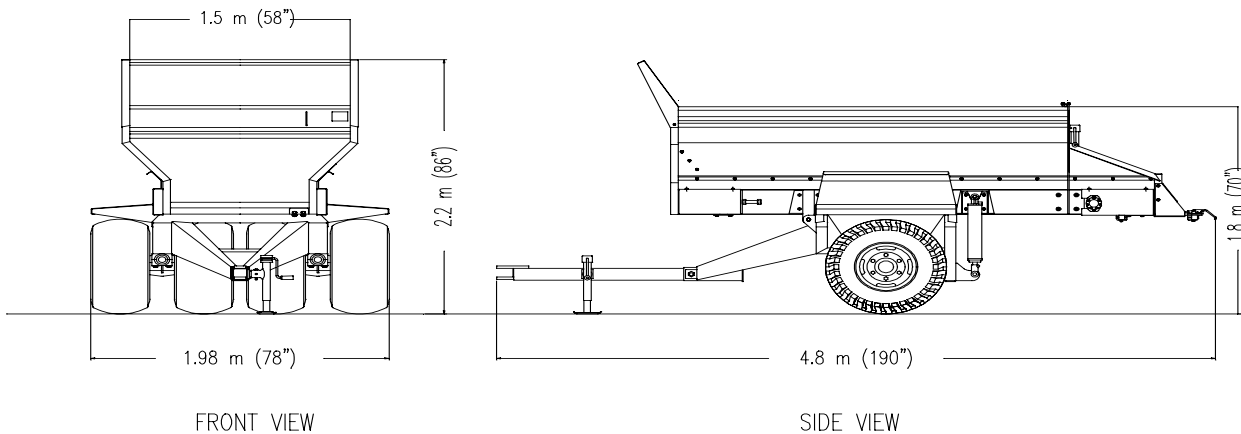

Important: These specifications are subject to change without notice. They are provided for reference only. Contact an authorized TYCROP Distributor for up-to-date or additional information.